



Hand Crank

Reelcraft's Series 400000 reels are designed for heavy duty applications requiring long lengths of hose and will adapt to plant or field uses.

For motor driven and hand crank reel accessories see pages 36 and 37. Optional bevel crank #600526-2 and chain shroud #600519 available on motor driven models. Reels can also be ordered without the swivel to be used as storage reels for cable, cord, rope, hose, extension cords and numerous additional applications.

In Europe for all thread connections over 1/2" add the suffix number 70 to indicate BSPT threads - example C421124 L70.

FEATURES

- Unitized all bolted construction
Reel, frame, spool and drum are fabricated of heavy gauge steel
- Swivels available with Buna "N" or Viton® "O" ring seals. Viton are standard
- Temperature operating range -20° F (-29° C) to +210° F (99° C)
- Manual driven reels can be converted to electric or air driven with motor mounting at either end of reel
- Chain and sprocket partially shrouded for extra safety
- Durable baked on powder coat red finish standard

ADDITIONAL CONSIDERATIONS

- "D" dimension for hand crank direct drive reels is 29" (737mm) or 38" (966mm)
- See pages 38 and 39 for reel accessories
- Add 10" (254mm) to "A" dimension when crank is in the rewind position on bevel crank front position reels

CAUTION: To prevent drum damage fully extend and pressurize hose and wind on the reel. Series 400000 should always be wound under pressure.

MODEL NUMBER SIGNIFICANCE

DRIVE TYPE	SWIVEL SIZE	WIDTH OF SPOOL	POWER SOURCE	EXPLOSION PROOF
A - Air, Pneumatic motor drive B - Bevel crank - Front position C - Hand crank - Direct drive E - Electric driven, AC or DC	0 - No Swivel 1 - 1" (25mm) I.D. 2 - 1 1/4" (32mm) I.D. 3 - 1 1/2" (38mm) I.D.	15" - (381mm) 24" - (610mm) See "C" dimension on line drawing	12 - 12 Volt D.C. 24 - 24 Volt D.C. 10 - 115 Volt A.C. 6A - 6AM (Air Motor)	X

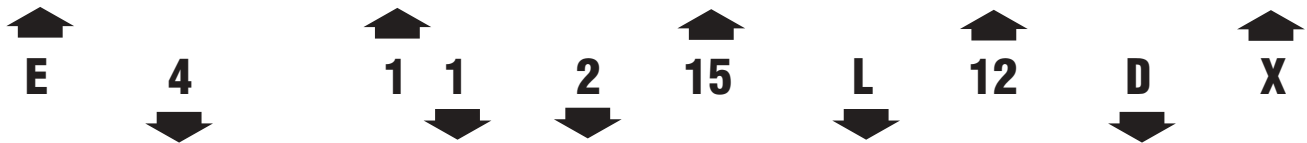

SERIES 400000	FLANGE DIAMETER	SPOOL SPACER DIAMETER	PRESSURE TYPE	ELECTRIC CURRENT TYPE
	1 - 25" (63.5cm) 2 - 28" (71.12cm)	1 - 10 3/4" (27.31CM) 2 - 15 5/8" (39.69CM)	L - 600 P.S.I. (43 bar) M - 1000 P.S.I. (69 bar) H - 3000 P.S.I. (213 bar)	A - A.C. D - D.C.

Although Reelcraft offers over 800 different models some of the above options are not available. Check with manufacturer for price and availability. Motor driven & hand crank accessories, see pages 36 and 37.

LARGE FRAME REELS

Series 400000

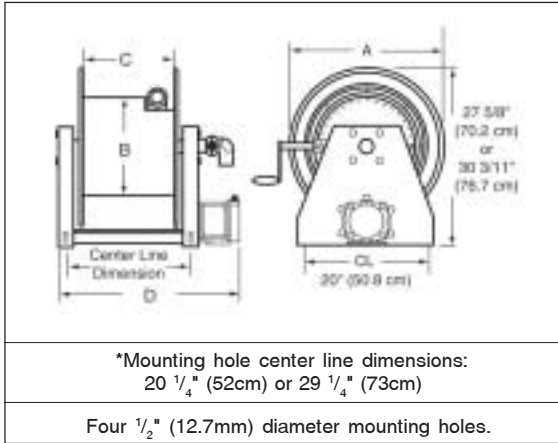

All 400000 series reels are supplied without hose, 1" hose assemblies will be quoted upon request. The most popular models are listed below. Inlet is NPTF (F) and matches swivel size.

Weights listed are for crank driven - Add for power driven, electric - all explosion proof 45 lb. (20.41kg); 12 Volt D.C. 1/3 H.P. 30 lb. (13.61kg); Air 6 AM 36 lb. (16.33kg) Note: Capacity chart is for reference only.

HOSE CAPACITY & REEL DIMENSIONS

WIDTH OF SPOOL "C"	SPOOL SPACER DIA. "B"	HOSE CAPACITY IN FEET							
		HOSE I.D.	1" (25.4mm)	1" (25.4mm)	1 1/4" (31.8mm)	1 1/4" (31.8mm)	1 1/2" (38.1mm)	1 1/2" (38.1mm)	
		HOSE O.D.	1 7/16" (35.8mm)	1 7/16" (35.8mm)	1 3/4" (44.5mm)	1 3/4" (44.5mm)	2" (51.6mm)	2" (51.6mm)	
15" (38.1cm)	15 5/8" (38.1cm)	FLANGE "A"	25" (63.5cm)	28" (71.1cm)	25" (63.5cm)	28" (71.1cm)	25" (63.5cm)	28" (71.1cm)	
		WGT	180 lb (81.7kg)	110' (33.5m)	65' (18.8m)	95' (29m)	50' (15.3m)	75' (22.9m)	
15" (38.1cm)	10 3/4" (61cm)	WGT	177 lb (80.3kg)	140' (42.7m)	190' (57.9m)	115' (35.1m)	165' (50.3m)	80' (24.4m)	130' (39.6m)
		WGT	201 lb (91.2kg)	125' (38.1m)	175' (53.4m)	100' (30.5m)	150' (45.7m)	75' (22.9m)	125' (38.1m)
24" (61cm)	15 5/8" (38.1cm)	WGT	195 lb (88.5kg)	230' (74.1m)	300' (91.5m)	180' (54.4m)	240' (73.2m)	130' (39.6m)	175' (53.4m)
		WGT	195 lb (88.5kg)	230' (74.1m)	300' (91.5m)	180' (54.4m)	240' (73.2m)	130' (39.6m)	175' (53.4m)

MODEL NUMBER	HOSE I.D. in / mm	HOSE O.D. in / mm	CAPACITY ft / m	WEIGHT lbs / kg	PRESSURE psi / bar	A in / mm	B in / mm	C in / mm	D in / mm
HAND CRANK REELS									
C 411215 L	1" 25.4	1 7/16" 38.5	80' 24	135# 61	600 41	25" 635	15 5/8" 397	15" 381	N/A
C 412215 L	1" 25.4	1 7/16" 38.5	110 34	180 81	600 41	28 712	15 5/8" 397	15 381	N/A
C 421224 L	1 1/4" 32	1 3/4" 44	100 30	201 96	600 41	25 635	15 5/8" 397	24 610	N/A
C 432215 L	1 1/2" 38.1	2" 50.8	75 23	157 71	600 41	28 712	15 5/8" 397	15 381	N/A
C 432224 L	1 1/2" 38.1	2" 50.8	125 38	201 96	600 41	28 712	15 5/8" 397	24 610	N/A
C 431215 L	1 1/2" 38.1	2" 50.8	50 15	157 71	600 41	25 635	15 5/8" 397	15 381	N/A
BEVEL CRANK DRIVEN REELS									
B 411115 L	1" 25.4	1 7/16" 38.5	140' 43	124# 56	600 41	25" 635	10 3/4" 273	15" 381	35" 889
ELECTRIC MOTOR DRIVEN REELS									
E 421224 L 12D	1 1/4" 32	1 3/4" 44	100' 30	231# 105	600 41	25" 635	15 5/8" 397	24" 610	38 1/2" 978
E 432215 L 12D	1 1/2" 38.1	2" 50.8	75' 23	210# 96	600 41	28" 712	15 5/8" 397	15" 381	27 1/2" 694
E 431215 L 12DX	1 1/2" 38.1	2" 50.8	50' 16	225 101	600 41	25 635	15 5/8" 397	15 381	29 1/2" 759
E 431215 L 10AX	1 1/2" 38.1	2" 50.8	50' 16	194 87	600 41	25 635	15 5/8" 397	15 381	29 1/2" 759
E 412215 M 24DX	1" 25.4	1 7/16" 38.5	110 34	225 102	1000 69	28 712	15 5/8" 397	15 381	29 1/2" 759
AIR MOTOR DRIVEN REELS									
A 412115 L 6A	1" 25.4	1 7/16" 38.5	190' 58	216# 97	600 41	28" 712	10 3/4" 273	15" 381	28 1/2" 714
A 412215 L 6A	1" 25.4	1 7/16" 38.5	110 34	213 96	600 41	28 712	15 5/8" 397	15 381	28 1/2" 714
A 431215 L 6A	1 1/2" 38.1	2" 50.8	50 15	216 98	600 41	25 635	15 5/8" 397	15 381	28 1/2" 714

The above models represent an abbreviated listing of the more popular sizes, many more models are available. To order, see chart on page 20.