

STATIC DISCHARGE REELS

Series G 3000



Cable Included

Static discharge reels are used to ground equipment operating in hazardous atmospheres, such as fuel trucks or carts transferring flammable materials. When properly clamped to ground, the static discharge reel dissipates static electrical buildup and reduces the chance of sparking and the potential for explosion.

- Automatic spring rewind
- Rugged steel construction
- Compact enclosed design
- Positive ratchet lock
- Lock on/lock off switch
- Steel cable installed
- 100 AMP universal jaw-type grounding clamp
- Durable baked-on powder coat finish
- Stores cable quickly and easily
- Eliminates tangled cable
- Reduces the risk of fire and explosion

SPECIFICATIONS Includes cable installed on reel

MODELS	Cable Extended		"Y"	Cable Notes	Weight	
	ft	m			ft	m
G 3050	50'	15	N/A	Single 7 x 7 Stranded Steel*	12#	5.5
G 3050 Y	50	15	2 @ 15' (4.8 m)	35' (9.2m) plus dual 15' (4.6) for "Y"*** Total extension 50' (15m)	12	5.5
G 3050 N	50	15	N/A	Nylon covered cable**	12	5.5

* Static discharge reels are supplied complete with 3/32" OD steel aircraft cable.
DC resistance is approximately one ohm per 50 ft. of steel cable.

** Nylon covered cable (1/8" O.D.).

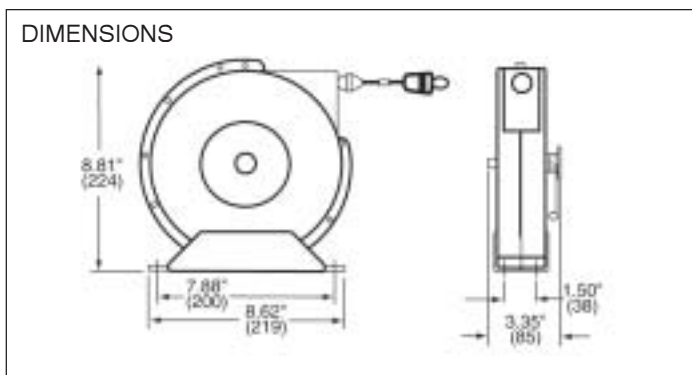

Four 3/8" (10mm) diameter mounting holes

APPLICATIONS

- Fueling Trucks
- Aviation
- Industry
- Flammable Containers
- Paint Shops
- Fuel Carts
- Flammable Powders
- Dockside Loading Facilities
- Refineries
- Chemical Plants